

# Cleaning and Maintenance Guide



## General

The slides pass through the printer under gravity so it is important to keep the guideway clean.

As and when the ribbon is replaced use the opportunity to:

- Check the guideway for dust or other materials that could obstruct the slide.
- Clean the print head.
- Check the tape is loaded correctly

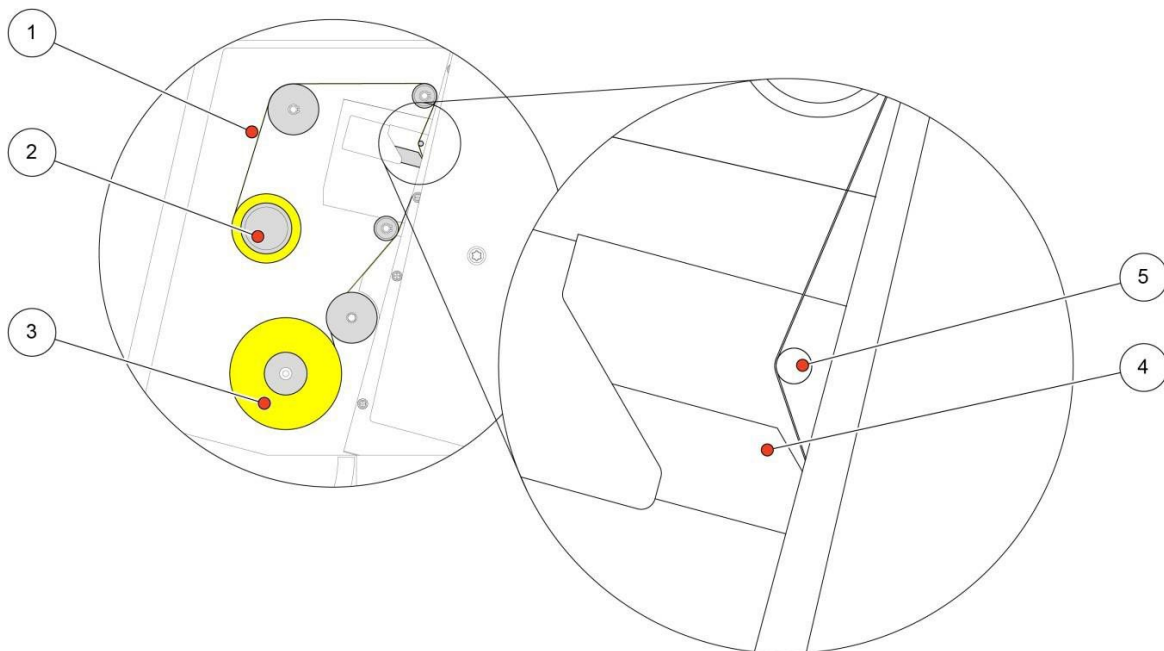

## Cleaning the Print Head

The Print Head should be cleaned every time the ribbon is changed or if any of the following occur:

- The print on the slide is showing signs of smudging.
- The print ribbon burns through or when the ribbon is loaded upside down.
- The quality is not the same as previously observed, most print quality issues are caused by the slide print surface. Check Print Quality Troubleshooting for possible causes first.



Avoid touching the print head surface with bare skin. Remove the print ribbon from the printer.

Remove a swab from the SlideMate AS cleaning kit (part no) and bend the tube at the swab end to release the solution. Rub the print surface edge (where the print head contacts the slide) of the print head firmly with the swab. Do this several times until no residue is visible.

Let the print head dry for two minutes before loading the ribbon.

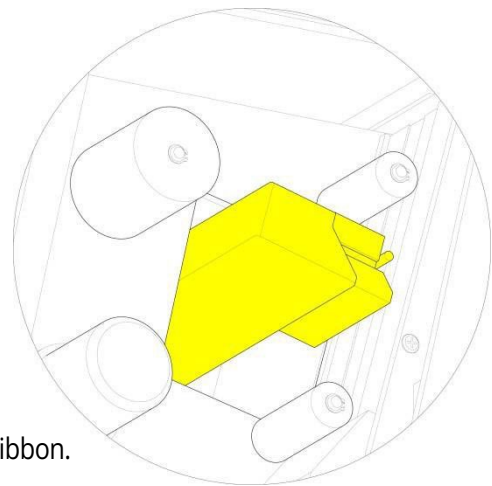

## Print Head Recovery Process

The print head can become stuck in a mode that prevents the heat settings working. This is caused by the head over heating.

1. Clean the print head to ensure it is clean and free of any debris.
2. Select a template and reduce the heat setting to the lowest possible setting.
3. Print 10 – 20 slides
4. The print will probably be light but still check for signs of smudging.
5. Increase the heat setting slightly and print another set of slides.
6. Check for signs of smudging.
7. Repeat this until you are getting a reasonable print without any signs of smudging. If there are any signs reduce the heat, if they persist clean the head again and start the recovery process from the start.
8. Keep checking for signs of smudging for the next 50 slides.