



Tissue Section Bath (Glass Bowl) - LED

User Manual

Tissue Section Bath (Glass Bowl) - LED

Thank you for purchasing this piece of small laboratory equipment. To get the best performance from your equipment and for your own safety please read these instructions carefully before use.

Contents

General Notes	3
Specimen Safety	3
User Safety	4
Power Lead and Connection	5
Specification	6
Location	7
Features and Controls	8
Operating Instructions	9
Cleaning Instructions	10
Miniature Circuit Breakers	11
Safety Cut Out	11
Portable Appliance Testing	11
Calibration and Offset Instructions	12
Routine Inspection Recommendations	14
Spare Parts List	15
Wiring Diagram	16
Troubleshooting Guide	17
Warranty Terms and Conditions	21
Non Warranty Information	22
EC Declaration of Conformity	26



General Notes

- 1 This product is designed for laboratory use only.
Always follow good laboratory practice.
- 2 If this product is not used in accordance with these instructions then basic safety protection may be affected.
- 3 If damaged or in case of failure the power cord supplied with this product should be replaced with an equivalent power cord.
- 4 Before using any cleaning or decontamination method please refer to the Maintenance and Cleaning section to ensure the proposed method will not damage the unit.
- 5 Connect only to a power supply with the corresponding voltage to that specified on the rating label positioned on the rear of the unit.
- 6 Ensure that the power supply has an earth (*ground*) terminal.

Specimen Safety

In the event of this instrument malfunctioning, all specimens that have been in contact with the device should be checked to ensure no harm or damage to the specimen has been caused.

AMENDMENTS

Issue 1: January 2026



This symbol appears in documents and on equipment to warn the user that there are hot surfaces on the equipment.



This symbol appears in documents and on equipment to warn the user that instructions must be followed to ensure correct or safe operation.

User Safety

The equipment you have purchased complies with the following European Directives EMC Directive Electromagnetic Compatibility and Low Voltage Directive as indicated in the EC Declaration. This instrument has been designed and constructed in a manner which minimises the risk of electrical shock to the operator, offers maximum protection from overheating and provides clear and adequate labelling of instrument controls. The instrument requires no regular servicing, but StatLab do recommend an annual inspection, as detailed in the manual which will prolong the life of the instrument to ensure continued safety.



WARNING - Risk of electric shock.
Do not touch any electrical contacts or open any closure plates.

DO NOT:

- 1 Use for heating organic or corrosive fluids.
- 2 Operate without water in the glass bowl.
- 3 Operate without a glass bowl fitted to the instrument.
- 4 Operate with any glass bowl other than the glass bowl supplied with the instrument.
- 5 Use metal instruments or scouring agents to clean the bowl.
- 6 Over or under-fill the glass bowl. The recommended water level to be within 25mm of the bottom of the glass bowl and 5mm from the top of the bowl.
- 7 Immerse in water for cleaning.

DO:

- 1 Position the unit so it can be disconnected from the power supply with ease.
- 2 Only use specified LED Lighting Rig/Probe with this water bath.

Power Lead and Connection to Electrical Supply



WARNING - The product must be earthed. If in doubt consult an electrician. Check the electrical supply is compatible with the rating label.

Where the mains supply or plug connection differs refer to local regulations or consult an electrician.

To ensure safe and reliable operation of the equipment, please observe the following practices when connecting the supplied power lead:

1 Use a Dedicated Wall Receptacle

- Connect the equipment directly to a properly installed wall receptacle (wall plate socket) using the supplied power lead.
- Ensure the wall receptacle shows no signs of overheating, such as discoloration, melting, charring, or heat tarnish on the receptacle face, contacts, or surrounding wall plate.

2 Do Not Use Multi-Way Adaptors or Power Strips

- Do not connect the equipment power lead to:
 - Multi-way adaptors
 - Extension cords
 - Power strips or relocatable power taps
- These devices can introduce excessive resistance, poor contact integrity, and unintended load sharing, which may lead to overheating or equipment damage.

3 Ensure Proper Neutral Configuration

- The wall receptacle supplying the equipment must not share a neutral conductor with another receptacle or branch circuit.
- Shared or improperly configured neutrals can result in elevated neutral currents, voltage imbalance, and overheating, potentially damaging:

- The equipment
- The power plug and cord
- The wall receptacle itself

4 General Safety Check

- If the receptacle, plug, or power cord feels warm to the touch, or overheating, discontinue use immediately and have the electrical installation inspected by a qualified electrician.

Specification

The Standard Illuminated Tissue Flotation Bath (*Glass Bowl*) - LED is a small footprint instrument designed to take up minimum space at the microtome, offering both reliability and ease of use to end users. Digital temperature control accurately maintains water at a set temperature, which enables tissue sections be efficiently flattened prior to being picked up with a microscope slide.

The 2 colour LED illumination allows tissue sections to be easily visualised and aids users in identifying and removing tissue debris/fragments from the surface of the bath between each case. A removable glass bowl enables users to easily fill and empty the bath without the need to move the instrument. The bath also features additional safety features such as an over temperature cut out and miniature circuit breakers.

Dimensions:	Width: 325mm	Display:	±1°C sensitivity
	Depth: 325mm		
	Height: 100mm	Bowl Dimensions:	Width 190mm
Weight:	4.5kg	(Internal)	Depth 60mm
Temp Range:	30°C to 60°C		Length 250mm
		Volume:	2.1 litre

Electrical Supply:	110 - 120V a.c. 50-60Hz
Safety:	Class 1 cut out
Power Rating:	200 watts
Altitude:	≤ 2000m
Pollution Degree:	2

Location

The product must be placed on a smooth, level and sturdy work surface. Suitable for use in ambient temperatures 5°C to 40°C with a maximum humidity 80% (*temperature 31°C*) decreasing to 50% (*temperature 40°C*).

Environment

This instrument is required to comply with the European Union's Waste Electrical and Electronic Instrument (*WEEE*) Directive 2012/19/EU and the UK Waste Electrical and Electronic Instrument (*WEEE*) Regulation 2013. It is marked with the following symbol:



This product should be returned to StatLab for disposal and recycling.

Features and Controls

- 1 Waterbath Temperature Controller** – Used to set temperature of water bath. Displays current and set temperature.
- 2 Heater On Lamp** – Illuminates orange when the water bath is heating.
- 3 Back lit On/Off button** - Power switch for waterbath.
- 4 Dimmer Control** – Used to vary intensity and turn white LED light On/Off.
- 5 Dimmer Control** – Used to vary intensity and turn blue LED light On/Off.
- 6 Glass Bowl** – Removable water bath glass bowl.
- 7 LED Light Rig/Temperature Probe** – Used to illuminate water in glass bowl and to ensure accurate temperature control of water.

- 8 Circuit Breakers** – Used to protect instrument from damage caused by overcurrent/overload or short circuit. Push to reset circuit breakers.
- 9 Power Entry Module** – Connection point for power cable.

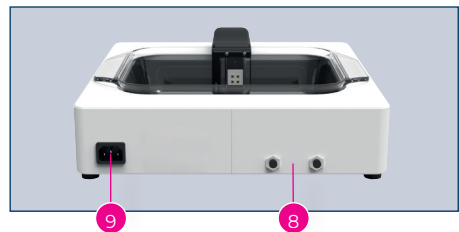
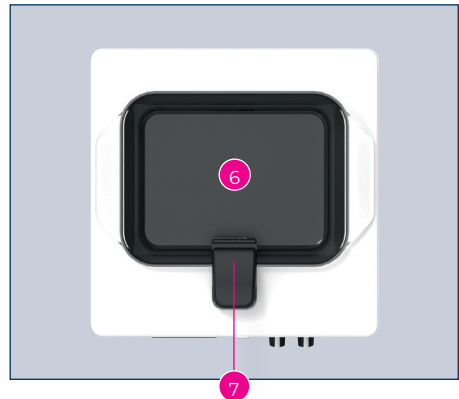
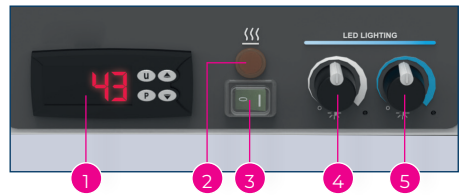

Operating Instructions

- 1 Fill the glass bowl with water. The recommended water level to be within 25mm of the bottom of the glass bowl and 5mm from the top of the bowl.
- 2 Fit the glass bowl onto the Tissue Section bath.
- 3 Fit the LED Light rig onto the Tissue Section bath.

When fitted correctly the LED Light Rig/Probe should be positioned inside the glass bowl. The LED Light Rig/Probe acts both as a light source for illuminating the glass bowl and a probe for temperature control of the instrument.



WARNING – The Tissue Section bath will not operate if the LED Light Rig/Probe is not fitted.

WARNING – Do not allow the bath to run dry.

WARNING – Only LED lighting accessories which meet the manufacturers specifications should be used with this water bath.

- 4 Connect the mains plug to the electrical supply and switch on.
(Ensure the power supply is properly earthed).
- 5 Turn on the water bath.
- 6 Select the desired temperature.
 - A. Press button **P** then release it *(do not hold down button **P** for 5 seconds).*
 - B. The display will show **SP** alternating with the current set temperature.
 - C. To change the set temperature press the **UP** key to increase the value or **DOWN** to decrease it. These keys increase or decrease the value one digit at a time, but if the button is pressed for more than one second the value increases/decreases rapidly, and after two seconds pressed, the speed increases even more to allow the desired values to be reached rapidly.

D. Exiting the Set mode is achieved by pressing the **P** key or automatically if no key is pressed for 15 seconds. After that time the display returns to the normal function mode.

- 7 The heater indicator will illuminate to show heater activity.
- 8 The instrument will then warm up to the desired temperature. You will observe the temperature rise on the display.
- 9 The instrument is designed to warm up and reach working temperature within 45 minutes. The instrument will maintain the set working temperature at +/- 1°C, by alternating heating and cooling.
- 10 Use the variable dimmer controls to adjust the LED brightness of the white and blue LEDs for preferred tissue section contrast.

Cleaning Instructions

- 1 The lower case work of the Tissue Section Bath including the control panel, may be wiped using small quantities of mild detergent or polishes applied with a soft cloth.
- 2 The glass bowl should be emptied and refilled with clean distilled water at the end of each working day.
- 3 The glass bowl will require cleaning at regular intervals, using a minimal quantity of mild detergent applied with a soft cloth and then allowed to dry.
- 4 The LED Light Rig/Probe can be removed for cleaning using a soft cloth. Replace the jack socket cap to prevent an ingress of water.

Scouring pads or de-scaling agents must not be used to clean this instrument.

Miniature Circuit Breakers

Located on the rear of the bath. In the event of a fault, push back in to reset.

Frequent nuisance tripping of the miniature circuit breaker can be caused by connection to a multi-way power adapters, extension cords or power strips.

The instrument should be connected directly to a wall socket using the supplied power cord. Frequent nuisance tripping of the miniature circuit breaker can be caused by connection to a multi-way power adapters, extension cords or power strips. The instrument should be connected directly to a wall socket using the supplied power cord.

If fault situation continues, please contact your Service Engineer or StatLab.

Safety Cut Out



WARNING - Disconnect from electrical supply before continuing. Always investigate the cause reason for safety device operation.

Instrument is fitted with a self resetting safety cut out.

Portable Appliance Testing

Portable appliance testing should be carried out by a qualified person.



This equipment must NOT be flash tested!

Calibration and Offset Instructions

Tissue Section Bath has a factory offset value programmed into the temperature controller, this aligns the set temperature with actual factory setting 45°C +/-1°C. To calibrate the instrument for your application:

- 1 Fill the bath with distilled water to a level 5 mm from the top/rim of the bowl.
- 2 Turn on the Tissue Section Bath.
- 3 Set the desired temperature following the Operating Instructions.
- 4 Allow the instrument to warm up for 60 minutes before taking a temperature reading, this will allow the temperature of the water in the bath to equilibrate.
- 5 Measure the temperature of the bath using a calibrated thermometer or calibrated digital liquid probe. The probe or thermometer should be positioned in the centre of the bath to a depth between 10 to 15mm from the surface the water.
- 6 The Tissue Section Bath has a sensitivity of $\pm 1^{\circ}\text{C}$. If the temperature measured using the reference probe is within $\pm 1^{\circ}\text{C}$ of the temperature shown on the display of the bath then the instrument is calibrated correctly, and no further action is required. If the temperature measured using the reference probe is within lower or higher than the temperature shown on the display by more than $\pm 1^{\circ}\text{C}$ then the instrument will need to be re-calibrated.
- 8 Follow the steps outlined in 'Setting Controller Offset Parameters' to recalibrate the instrument.

Setting Offset Parameters:

- 1 Press and hold the **P** button until **r.P** is displayed then press the **P** button until **0** is displayed.
- 2 Use the **UP** arrow button to increase the number to **146**.
- 3 When **146** is displayed press the **P** button. **S.LS** is displayed.
- 4 Press the **DOWN** arrow button to cycle through the sub menus until **I.C1** is displayed.
- 5 When **I.C1** is displayed, press the **P** button. The display will now show a number, this number is the current adjustment (*offset*) applied to the temperature display. This was the adjustment (*offset*) which was used when the Tissue Section Bath was manufactured to calibrate the instrument.
- 6 Use the **UP** and **DOWN** arrows to select the correct adjustment to match the temperature shown on your reference thermometer.

Example: If the temperature indicated on the section bath display originally shows 45°C and the probe/thermometer used to check the temperature of the bath indicates 43°C then the offset value should be reduced by 2 digits. If the original offset was 2 then the new offset would be 0. If the original offset was 0 then the new offset would be -2.

Then press the **P** button to set the adjustment (*offset*).

- 7 Press and hold the **U** button to return to the main menu.

Routine Inspection Recommendations

StatLab recommend that a simple annual inspection be made for all Small laboratory equipment in order that any malfunction can be identified and rectified as early as possible. This is to ensure user safety and prolong instrument life span.

Recommended checks to be made:

- 1 Condition of Power Lead. A visual inspection to ensure the insulation is not damaged and that the correct fuse is fitted.
- 2 When a power lead replacement is necessary, do not replace with an inadequately rated MAINS lead, only fit a type of the same specification to maintain safety.
- 3 Functioning of Heater On Lamps. Heater lamps should be on when the water bath and hotplate warming up.
- 4 Glass bowl should be free of scratches, crack and chips.
- 5 White and Blue LED lights in the Light Rig/Probe should both operate.
- 6 Before servicing equipment empty water, allow equipment to cool and disconnect from the power supply. Wipe and clean surfaces.
- 7 Ensure equipment is earthed.
- 8 Complete earth and insulation tests before recommissioning back into use.

Spare Part List

Item Code	Description	Qty
JBA-EE0725-00A	Silicone Heater Element 250W	2
JBA-EX1175-00A	Digital Temperature Controller	1
JBA-ES0272-00A	Mains Switch	1
JBA-EL0100-00A	Neon Amber and Tags	1
JBA-EX1151-00A	Power Entry Module	1
JBA-EX1161-00A	3A Circuit Breaker	2
JBA-ET1314-00A	Temperature Sensor – PTC	1
JBA-EH1163-00A	Thermal Cut Out	1
JBA-SA2067-00A	LED Light Rig/Probe	1
SI-TWB-GLASSBOWL	Replacement Glass Bowl	1
SI-TWB-ALUMINIUMBOWL	Replacement Aluminium Bowl	1
SI-TWB-LID	Flotation Bath/Workstation Lid	1

Wiring Diagram

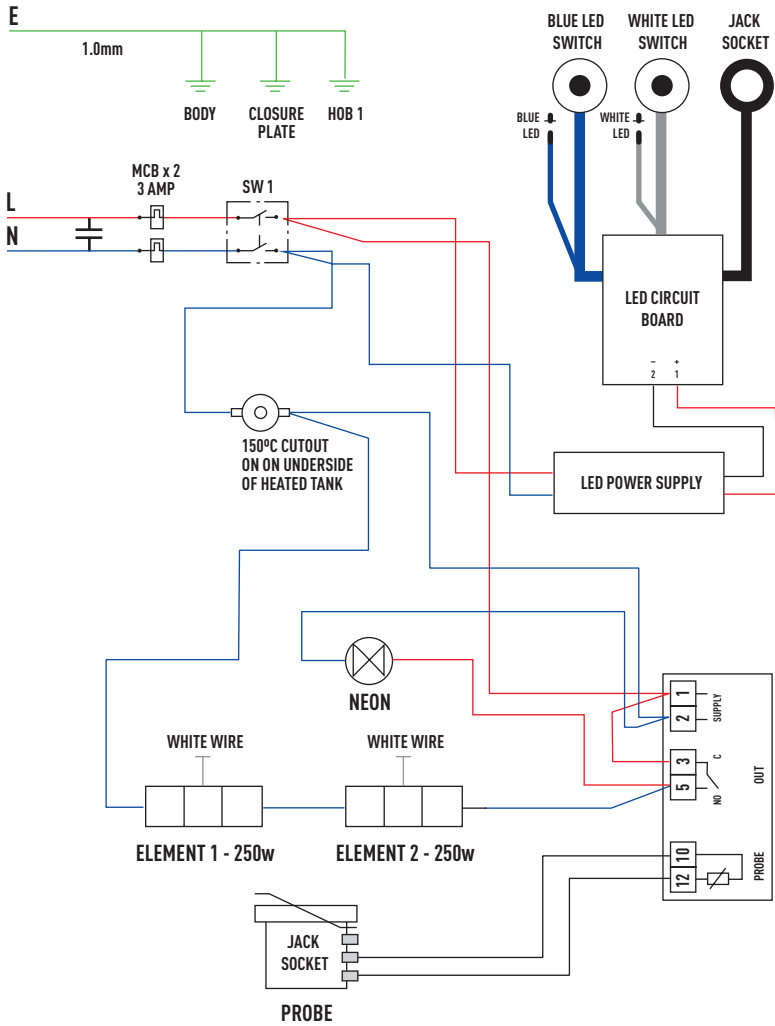

Troubleshooting Guide

Issue Description	Possible Cause	Action Required
<p>1. Unit does not operate/ No power to the instrument. <i>(Illuminated On/Off switch not lit.)</i></p>	<p>A: Unit is not switched on. B: Unit not plugged into power supply. C: Circuit breakers have been triggered and need to be re-set. D: Fuse in instrument lead plug has failed. E: Power supply failure.</p>	<p>A: Switch On B: Plug in, and switch on unit. C: Re-set circuit breakers. D: Replace fuse or use a new lead set. E: Check that other electrical instruments on the same circuit are working. Check distributionboard for a triggered circuit breaker or blown fuse.</p>
<p>2. Power is supplied to the instrument, but the water bath does not heat. <i>(Temperature appears on controller screen but temperature does not rise on the controller and the orange heater light does not operate.)</i></p>	<p>A: Temperature of water bath is set too low. B: Heating element has failed. C: Temperature controller Parameters set incorrectly.</p>	<p>A: Check set temperature of the water bath. B: Instrument should be checked by a competent person. C: Instrument should be checked by a competent person.</p>
<p>3. Power is supplied to the instrument, but the water bath does not heat, and the display flashes 0000000.</p>	<p>A: Probe failure B: Lighting rig not inserted correctly.</p>	<p>A: Replace light rig B: Check light rig is inserted correctly.</p>
<p>4. Power is supplied to the bath, but the water bath does not heat. <i>(Temperature control display is blank and orange heater light does not operate.)</i></p>	<p>A: Self resetting cut out has activated.</p>	<p>A: Allow instrument to cool. Instrument will automatically resume operation. Cause of cut out activation to be investigated by competent person.</p>

Troubleshooting Guide

Issue Description	Possible Cause	Action Required
<p>5. Temperature of water bath seems to be fluctuating more than expected.</p> <p><i>(Expected temperature variation $\pm 1^{\circ}\text{C}$ from the set temperature.)</i></p>	<p>A: Temperature control circuit fault.</p>	<p>A: Instrument should be checked by a competent person.</p>
<p>6. Temperature of the water bath shown on the controller, is different to the temperature of the water measured by a reference probe.</p>	<p>A: External temperature probe being used is not suitable for water temperature measurements or external probe is not calibrated.</p> <p>B: Position of the external temperature probe is not at the calibration point. Bowl should be filled to within 5 mm of the top of the bowl and a measurement taken 10mm from the surface of the water in the centre of the bowl.</p>	<p>A: Check correct probe is being used for measurement and that the probe is calibrated.</p> <p>B: Measure temperature at the position where the instrument is calibrated, using a calibrated probe.</p> <p>Users should wait at least 60 minutes before taking a measurement to allow the temperature of the water in the bath to equilibrate.</p> <p>If the temperature reading is significantly different, the instrument may need to be re-calibrated. Follow the calibration instructions.</p>
<p>7. Temperature of the water bath continues to rise when not expected.</p>	<p>A: Actual water bath temperature is lower than the set temperature.</p> <p>B: Temperature control circuit fault.</p>	<p>A: Check the set temperature.</p> <p>B: Instrument should be checked by a competent person.</p>
<p>8. LED lighting does not operate.</p>	<p>A: LED lighting not fitted correctly.</p> <p>B: White, Blue LEDs not turned on.</p> <p>C: LED Lighting Rig failure.</p> <p>D: LED lighting transformer failure or lighting rig connector failure.</p>	<p>A: Check LED lighting rig is fitted correctly.</p> <p>B: Check White, Blue LED switches are turned on and vary intensity using dimmer functions.</p> <p>C: Replace LED Lighting Rig.</p> <p>D: Instrument should be checked by a competent person.</p>

Troubleshooting Guide

Issue Description	Possible Cause	Action Required
<p>9: Frequent Tripping of Miniature Circuit Breakers</p>	<p>A: Instrument not connected directly to a power socket.</p> <p>B: Neutral configuration of electrical supply poor.</p>	<p>A: Connect instrument directly to a power socket.</p> <p>Do NOT connect power lead to:</p> <ul style="list-style-type: none"> · Multi-way adapters · Extension cords · Power strips <p>These devices can introduce resistance, poor contact integrity and unintended load sharing, which may lead to overheating or equipment damage.</p> <p>B: The wall receptacle supplying the equipment must not share a neutral conductor with another electrical socket or branch circuit.</p> <p>Shared or improperly configured neutrals can result in elevated neutral currents, voltage imbalance, and overheating, potentially damaging:</p> <ul style="list-style-type: none"> · The instrument. · The power plug and cord · The wall socket itself

Troubleshooting Guide

Issue Description	Possible Cause	Action Required
		<p>Repeated Neutral Circuit Breaker (MCB) tripping or tripping of the associated branch circuit breaker with an instrument connected directly to the electrical power supply may indicate an underlying issue with the power supply within that location.</p> <p>The installation should be evaluated and if required corrected by a licensed electrician before a decision is made to return the instrument to the supplier for investigation.</p>

Warranty Terms and Conditions

- 1 CellPath Ltd warrants to the Customer that the product purchased is free from defects in materials and workmanship.
- 2 Provided the terms of payment are duly complied with, CellPath Ltd undertakes to remedy any original defects arising from faulty materials or workmanship, in any goods manufactured/ supplied by CellPath Ltd, which under proper and normal conditions of use, may develop within a period of twelve months from the date of delivery.
- 3 In the case of components which by their nature of application have an unpredictable life, this guarantee shall only be to the extent of the guarantee given by the manufacturers of these articles.
- 4 CellPath Ltd will accept no liability, where in the opinion of the company the defect has been caused by damage due to the Customer's failure to follow operating instructions, correct installation, wear and tear, or damage due to the use of spare parts other than those spare parts of CellPath Ltd or which are recommended by CellPath Ltd, the defect has been caused by alterations or repairs being undertaken by a person(s) other than an authorised representative of CellPath Ltd.
- 5 Any damage claim must be in writing, and give the serial number and description of the goods, order number and date of delivery, and will not apply where any names or serial numbers or other information which may be attached to or inscribed upon the goods have been removed, covered up or defaced in any way.
- 6 Any goods or parts thereof, which may require repair or replacement, shall be repaired or replaced (*at the election of CellPath Ltd*) at the works of CellPath Ltd. The product to be repaired shall be delivered carriage paid back to CellPath Ltd by the customer at the Customer's risk and expense. Any such goods or parts will be delivered by CellPath Ltd

to the Customer free within the United Kingdom but if required to be borne by the Customer.

All faulty parts removed from the equipment will become CellPath Ltd's property. Any other repairs or work by CellPath Ltd will be carried out under the terms and conditions for specialist engineers currently in force.

- 7 In the event of replacement with a new or reconditioned model, the replacement unit will continue the warranty period of the original equipment.
- 8 If any goods or parts thereof are returned unnecessarily all cost involved, including a charge for inspection, handling and the return carriage must be paid by the sender. In no circumstances shall any of the goods be returned to CellPath Ltd without its prior written consent.
- 9 Please retain the original packaging over the warranty period. Any equipment returned under warranty should be in the original packaging. Any damages in transit resulting from using

any packaging other than that originally supplied will be the responsibility of the Customer.

Non Warranty Information

Spare parts shall be made available for a period of 5 years after a piece of equipment is discontinued.

CellPath Ltd

47 Mochdre Enterprise Park
Newtown
Powys
SY16 4LE
United Kingdom



EC Declaration of Conformity

We herewith confirm the following products:

Tissue Section Bath (Glass Bowl) - LED SI-TWB-GLASS/230

Conforms with requirements outlined by the following European Directives:

Low Voltage Directive 2014/35/EU

EMC Directive 2014/30/EU

RoHS Directive 2011/65/EU

UK Declaration of Conformity

Conforms with requirements outlined by the following United Kingdom Directives:

Electromagnetic Compatibility Regulations 2016

Electrical Equipment (Safety) Regulations 2016

RoHS Directive 2011/65/EU

Conforms with the requirements of the following standards:

BS EN 61010-1:2010 + A1:2019

BS EN 61010-2-010:2020

**Safety requirements for electrical equipment
for measurement, control and laboratory use**

BS EN 61326-1:2021

**Electrical equipment for measurement control
and laboratory use - EMC requirements.**

US and Canada Declaration of Conformity

Conforms with requirements of the following standards:

UL 61010-1 (3rd Ed.); Am. 1 /CAN/CSA C22.2 No. 61010-1; UPD1:2015; UPD2:2016; AMD1:2018; COR1:2019; UPD3:2023: Safety Requirements for Electrical Equipment for Measurement, Control, and Laboratory Use - Part 1: General Requirements.

CSA C22.2 NO. 61010-2-010:19/UL 61010-2-010: Safety requirements for electrical equipment for measurement, control and laboratory use Part 2-010: Particular requirements for laboratory equipment for the heating of materials.

We confirm the declaration:

Nickel Electro Ltd

Oldmixon Crescent
Weston Super Mare
North Somerset
BS24 9BL
United Kingdom

StatLab Medical Products

2090 Commerce Drive, McKinney, TX 75069

T: 1-800-442-3573 — E: orders@statlab.com — statlab.com

CellPath Ltd

80 Mochdre Enterprise Park, Newtown, Powys, SY16 4LE, UK

T: +44 (0)1686 611333 — E: sales@cellpath.com — cellpath.com

Diapath S.p.A.

Via Pietro Savoldini, 71 — 24057 Martinengo (BG) - IT

T +39 0363 986411 — info@diapath.com — diapath.com

Especialidades Médicas Myr, S.L.

Lleida, 17-23, 43712 Llorenç del Penedès, Spain

T: +34 977 66 80 20 — E: esp.medicas@myr.com.es — myr.com.es